

Detector Operations

John Kelley
Detector Operations Manager

IceCube Management and Operations
NSF Site Visit March 16, 2020



Outline

- Deliverables and Overview
- Hardware Maintenance
- Operational Improvements
- Preparations for the Future

Deliverables

- Keep the detector running!
 - reliable hardware and software
 - fast response time to problems
 - maintenance during austral summer at pole
- Ensure high-quality data to collaboration
 - monitoring and verification of every run
 - good / bad run tracking
- Support continued expansion of IceCube science
 - new features in software systems (e.g. multi-messenger program support)
 - design for integration of future detector expansions

Online Systems Overview

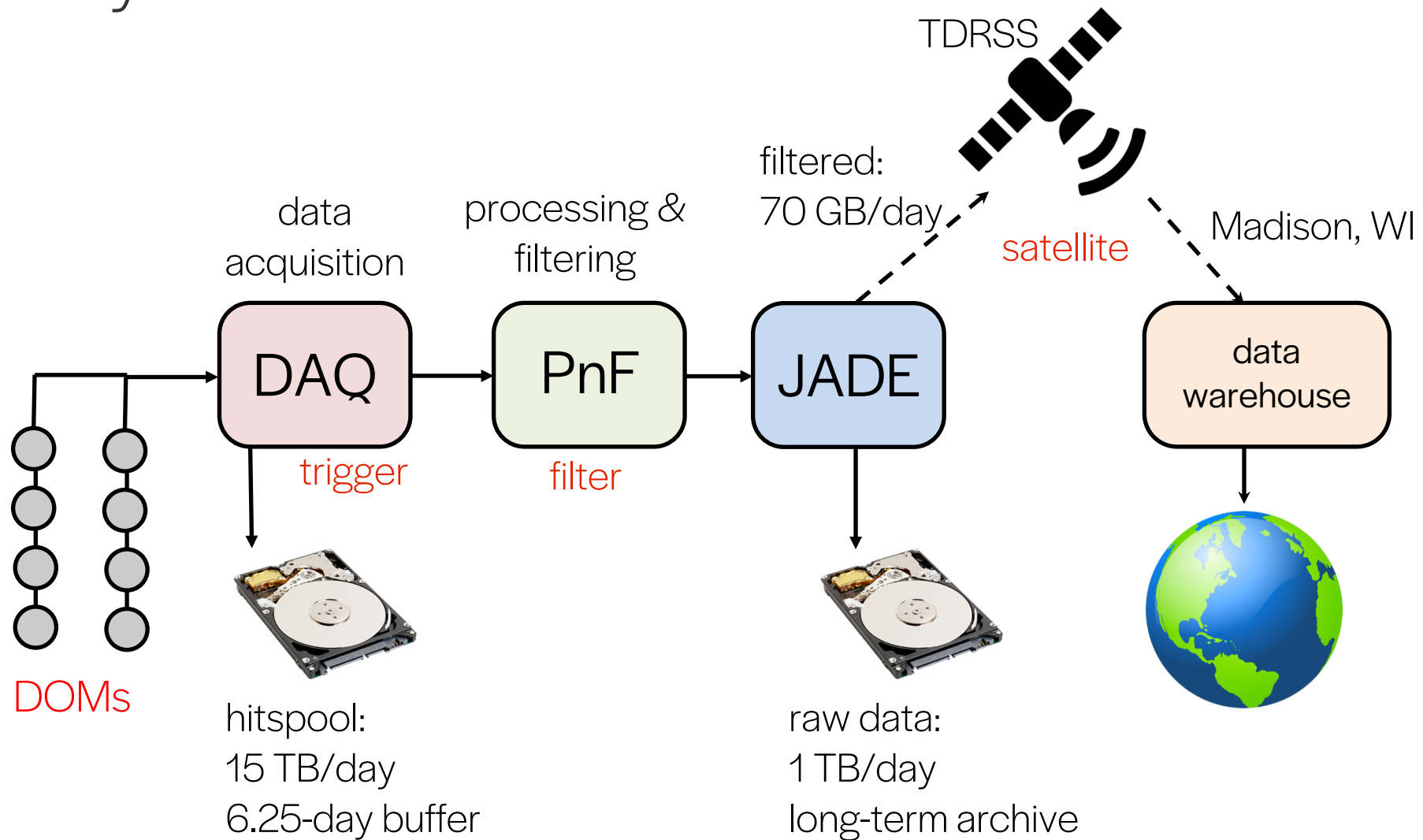

Triggers and Filters

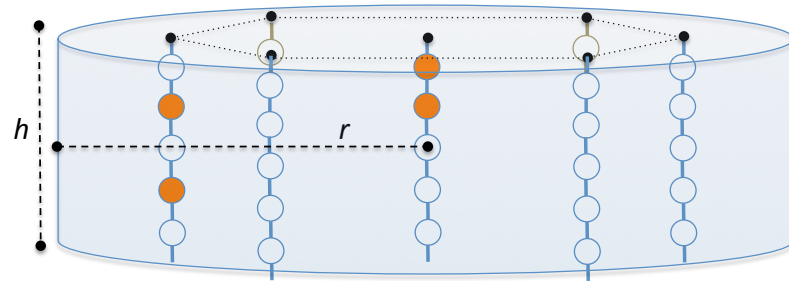

DAQ selects causal patterns of light (hits) from particle interactions

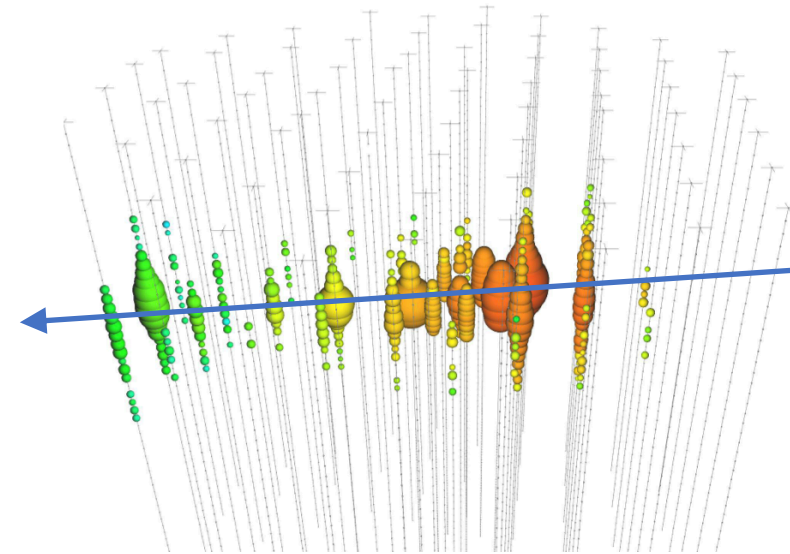

PnF performs fast reconstructions on those events, selects subsets interesting for analysis or real-time followup

Historical Detector Uptime

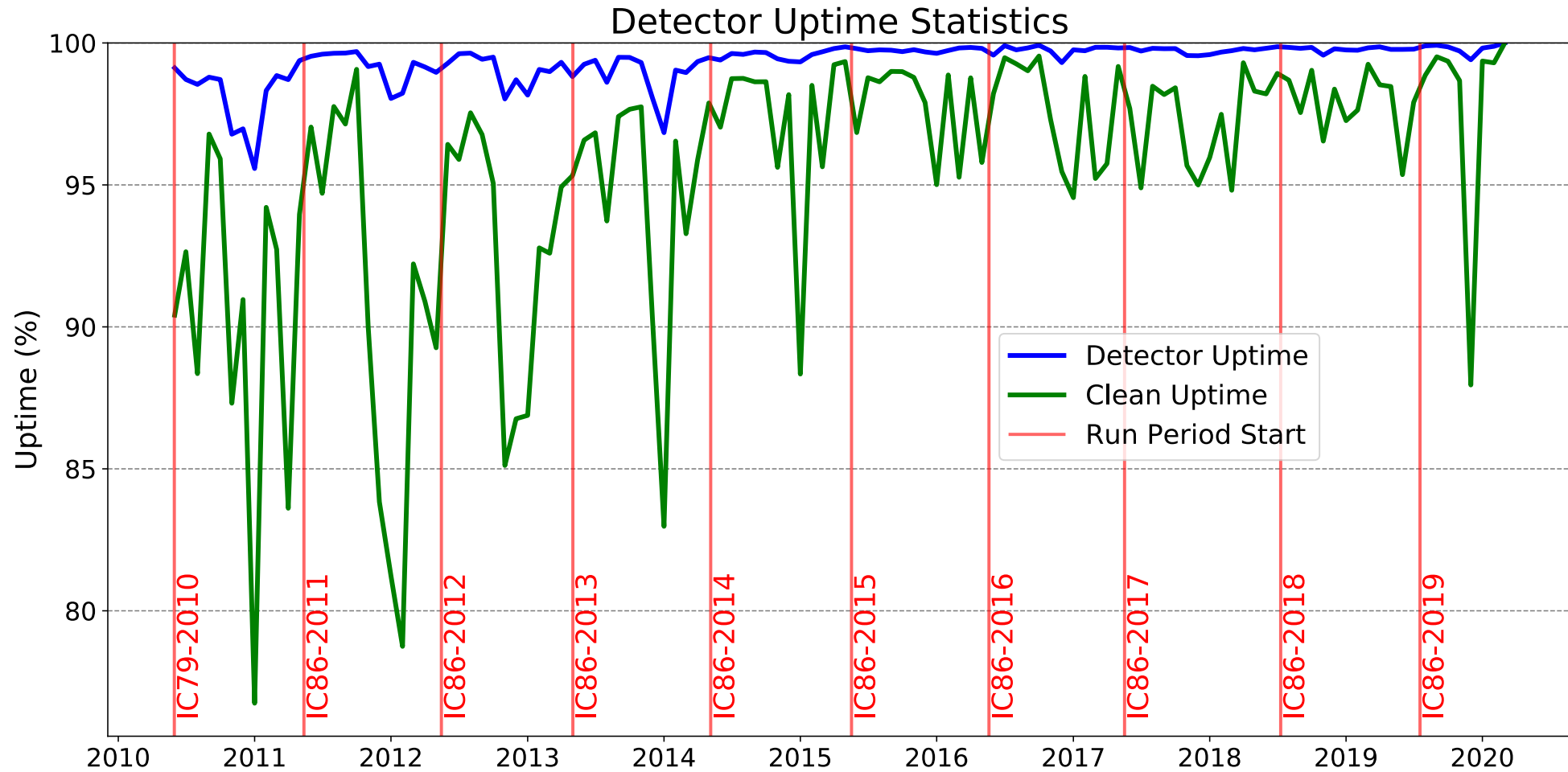

Detector Uptime

1 Apr 2019 — 28 Feb 2020

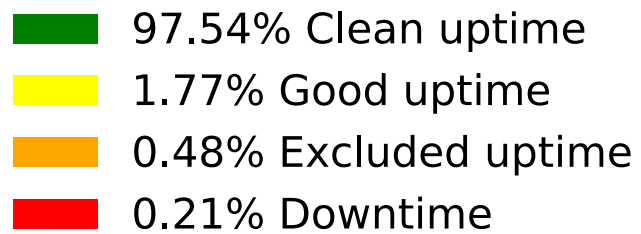
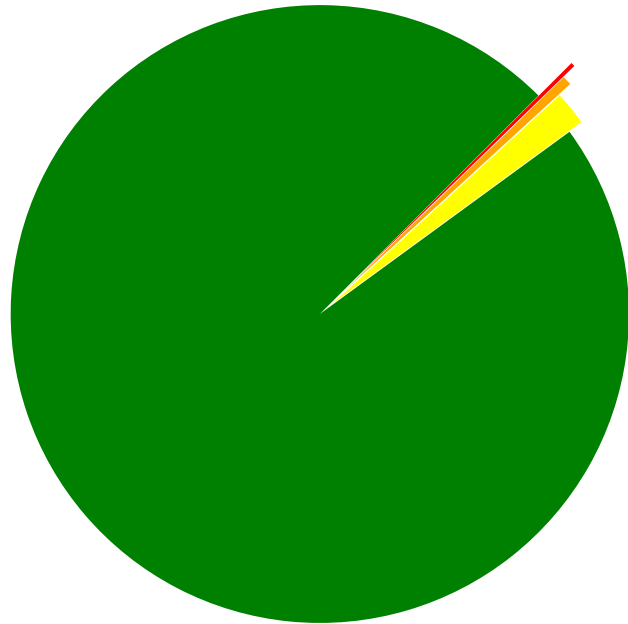

- Supported by a team of professionals
 - emphasis on testing, redundancy, and stability
- All hardware and software changes vetted on South Pole Test System (SPTS)
- 24/7 operational communications via Iridium
 - real-time detector status
 - winterover chat via IceCube Live + Slack
- Winterover paging system when intervention is needed

Hardware Maintenance

Inside the IceCube Laboratory (ICL)



- 18 racks of equipment
- 97 DOMHubs (1 / string + IceTop)
 - low-power single-board computers
 - custom DOM readout and clock fanout cards
 - DOM power supplies
- ~40 Dell PowerEdge servers
 - DAQ, PnF, infrastructure
- GPS receivers + fanouts, network switches, UPS, special devices

Computing Maintenance

- Regular “life-cycle” server replacements
 - 100% replacement in 2013–14
 - 50% replacement in 2018–19
 - 50% replacement in 2019–20
- UPS battery replacements
- Annual security software patches
- Operating system software upgrades
 - planned for 2020–21



Hardware Stability

Failures in this M&O period
(from April 1, 2016)

Component	Failures
DOM power supplies (Acopian)	46
Hub power supplies	50
Hub memory	2
Hub hard drives	5
Hub single-board computers	1
DOM readout cards	1
Clock fanout cards	5 (1)
DOMs	3
master clock	1

- Most custom electronics (including DOMs) still reliable
 - 80% of failed clock fanout cards repaired (fuse)
- Hub hard drive failure rate increased in 2018
 - full replacement in 2019–20 season (after 6 years)
- DOMHub power supply failure rate high since 2016
 - redundant, so failure has no impact on data-taking
- DOM power supply failure rate unacceptably high
 - NOT redundant; failure takes down a string until replaced

DOM Power Supply Upgrade

- Full replacement of Acopian power supplies in 2016–17
 - failure rate stabilized but did not decrease
- Acopian DOM power supplies swapped for Mean Wells
 - 50% completed in 18–19
 - 100% completed this season
 - **zero** failures as of Mar 2020
- Side benefit: increased efficiency
 - estimated power savings: 2.8 kW



Mean Well MSP-200-48
with custom pigtail

DOMHub (ATX) Power Supply Maintenance

- Winterovers discovered in 2019 that ~50% of DOMHub ATX power supply fans had failed
 - not surprising given MTBF of bearings
- Replaced ~200 dead fans this season with new model
- 15 modules with zero working fans died
 - sufficient spares



Master Clock Upgrade

- IceCube timing provided by GPS “master clock”
- Issues with legacy Symmetricom ET6000
 - buggy, unsupported firmware
 - instability with one unit at pole
- Identified replacement: Spectracom SecureSync
 - running at pole as White Rabbit master clock since December 2017
 - validation at South Pole Test System in summer 2018
 - primary master clock upgraded 2018–19
 - backup master clock upgraded 2019–20

Spectracom SecureSync 1200

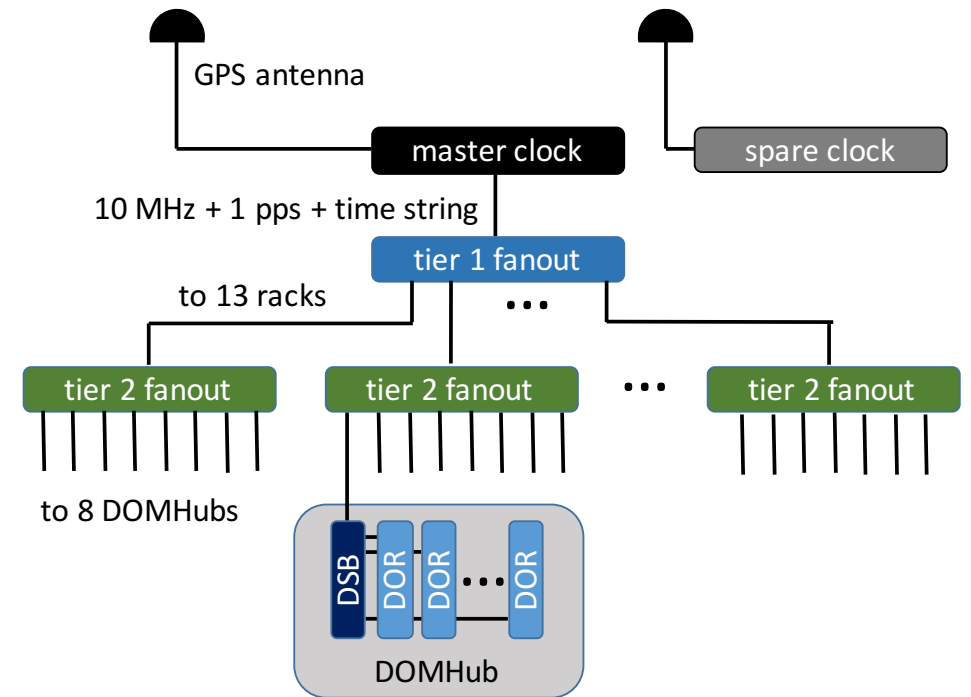

Planned Hardware Maintenance

- Network switch lifetime replacement (21–22)
- UPS lifetime replacement (22–23/23–24)
- Server lifetime replacement (23–24/24–25)
- DOMHub upgrade (24–25/25–26)
 - existing custom hardware has lasted 15–20 years, but difficult/impossible to replace
 - move to homogenous Upgrade-style hardware for efficient maintenance
 - requires firmware development

Upgrade mini-FieldHub

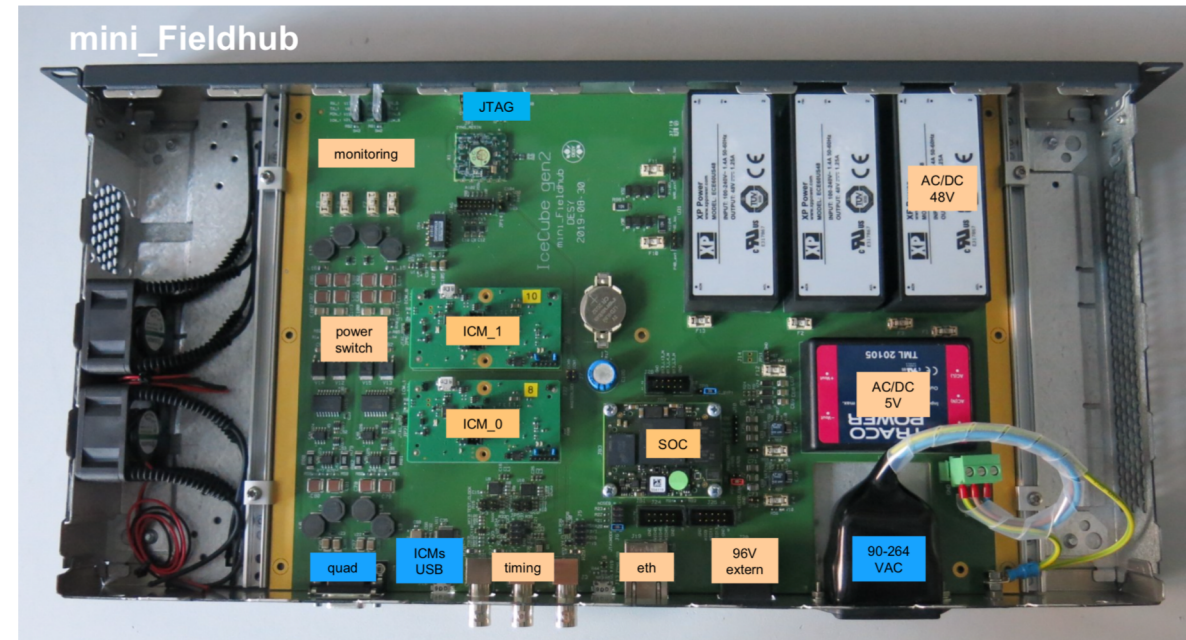

IceTop Maintenance

Impact and Mitigation of Snow Accumulation

- Increasing snow accumulation on tanks:
 - increases IceTop energy threshold
 - adds large systematic error to composition analyses
- Plan to restore efficiency and enhance cosmic-ray air shower reconstruction capabilities
 - elevated scintillator panels
 - broadband radio antennas

Snow Depth on IceTop tanks Oct/2016

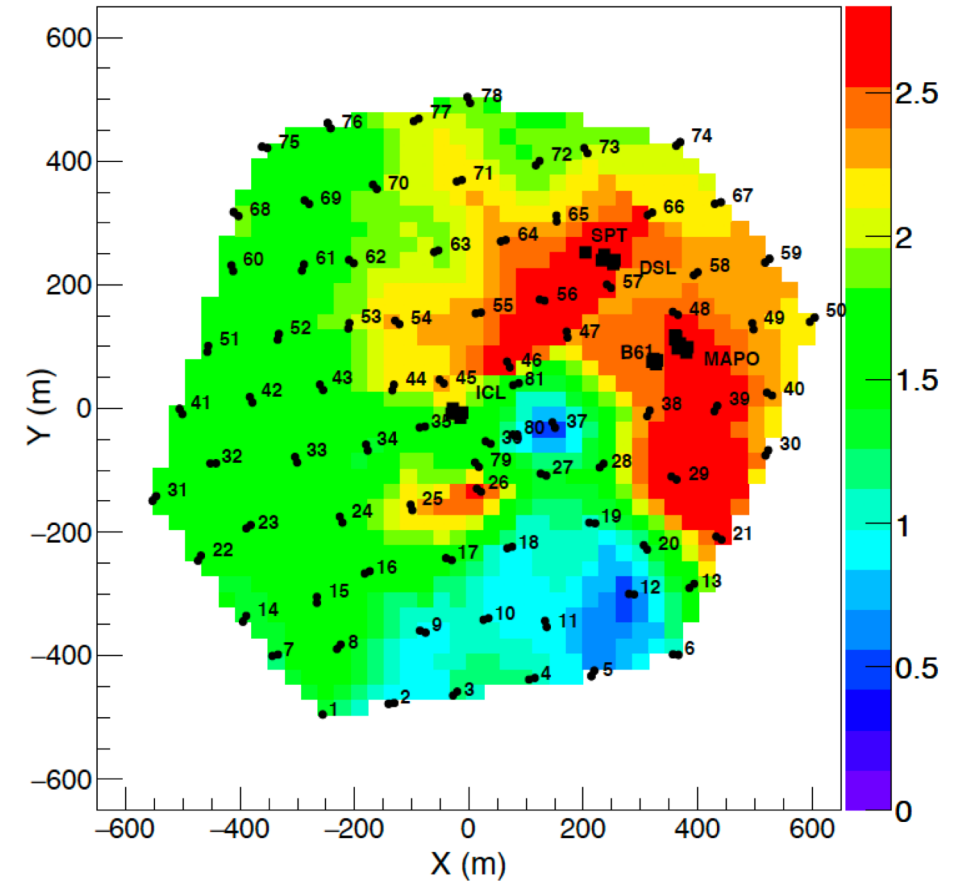

Surface Array Station Status

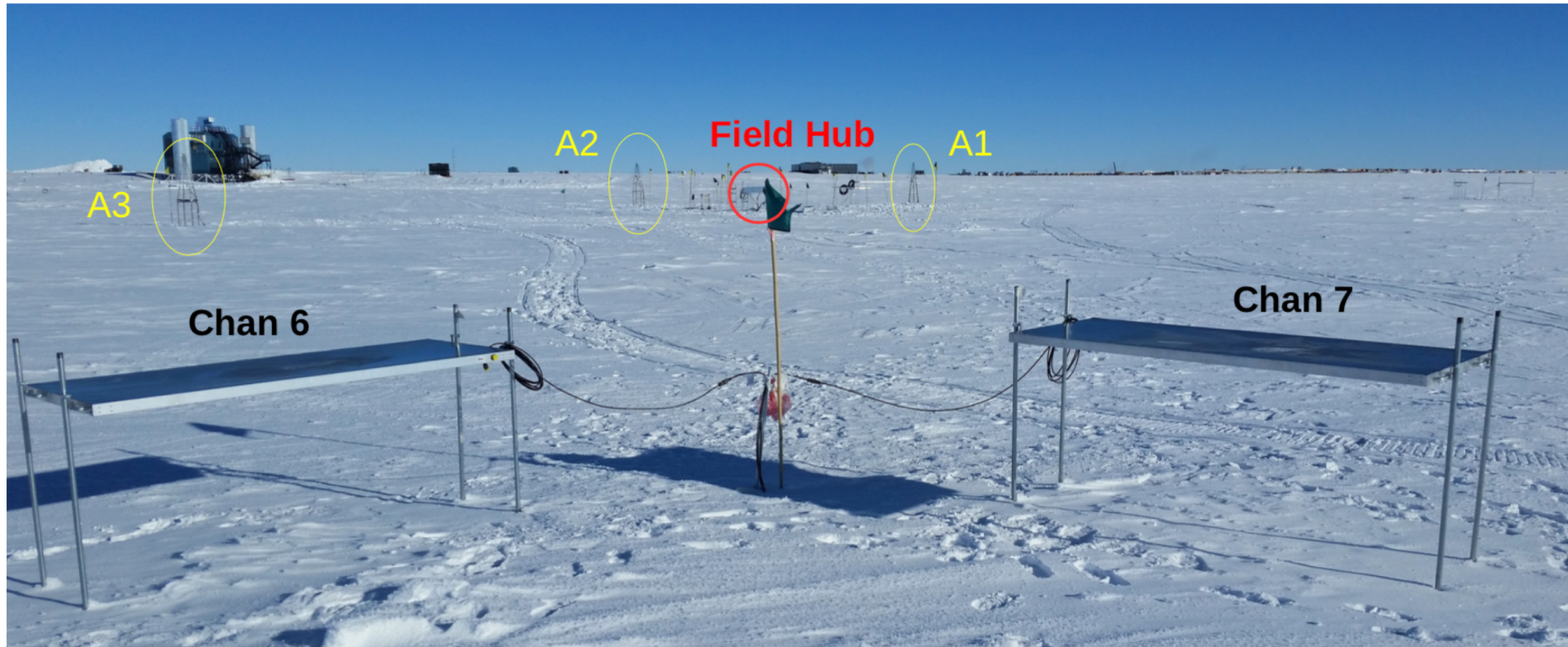

- Prototype hybrid station 2019–20 upgraded to production electronics
- All instrumentation and electronics elevated and able to be raised
- No induced snow drifting observed with previous deployments

Technology Platform for Upgrade and IceCube-Gen2

prototype elevated FieldHub

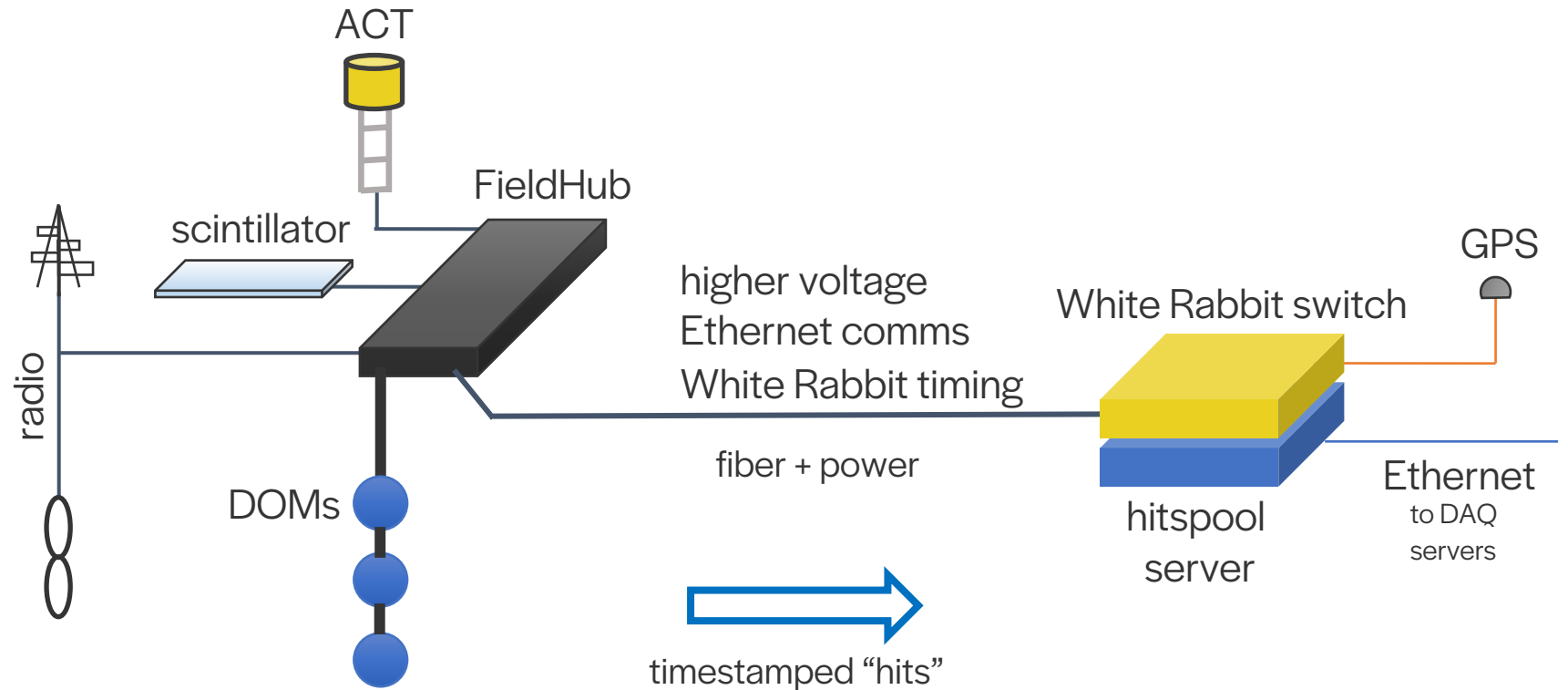
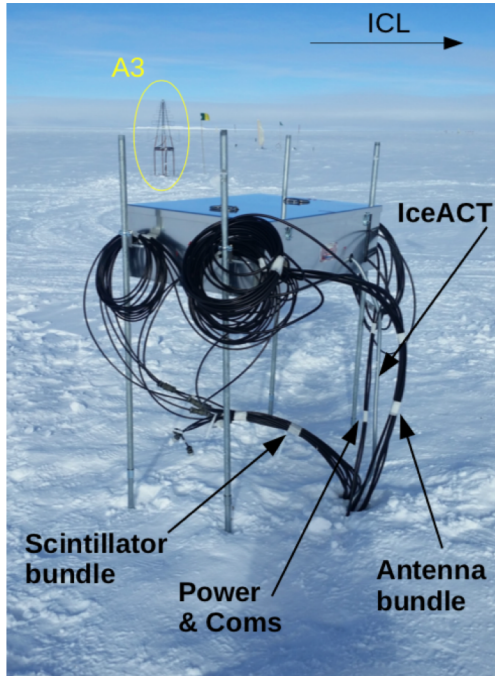

Standard comms/power/timing architecture supports a wide variety of instrumentation

Surface Array Upgrade

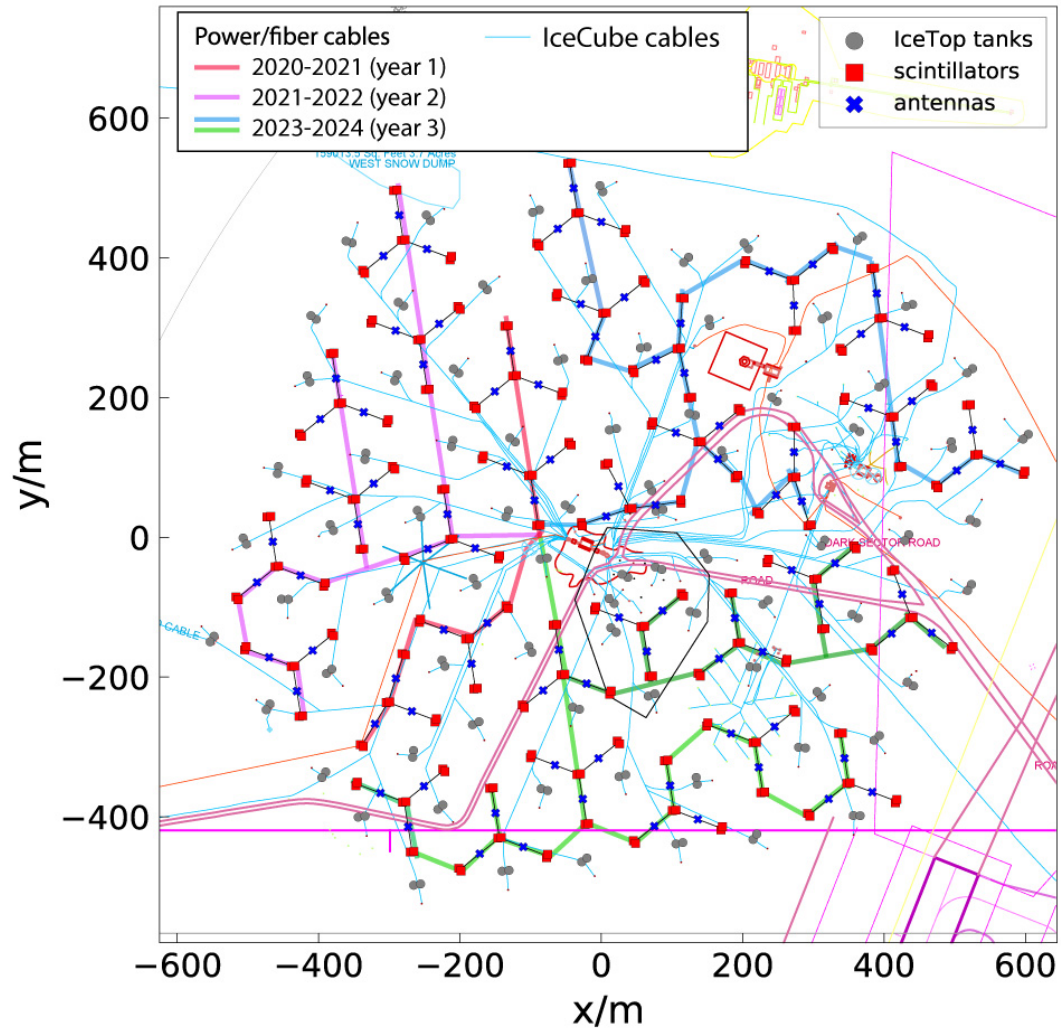

- Restore and enhance IceTop functionality with full scintillator + radio array
 - instrumentation funded by in-kind contributions
- Logistics discussed with stakeholders Nov. 2019
- Will be included in next M&O proposal
 - very limited activity 20–21 season

Additional Operational Improvements

External Hitspool Alerts

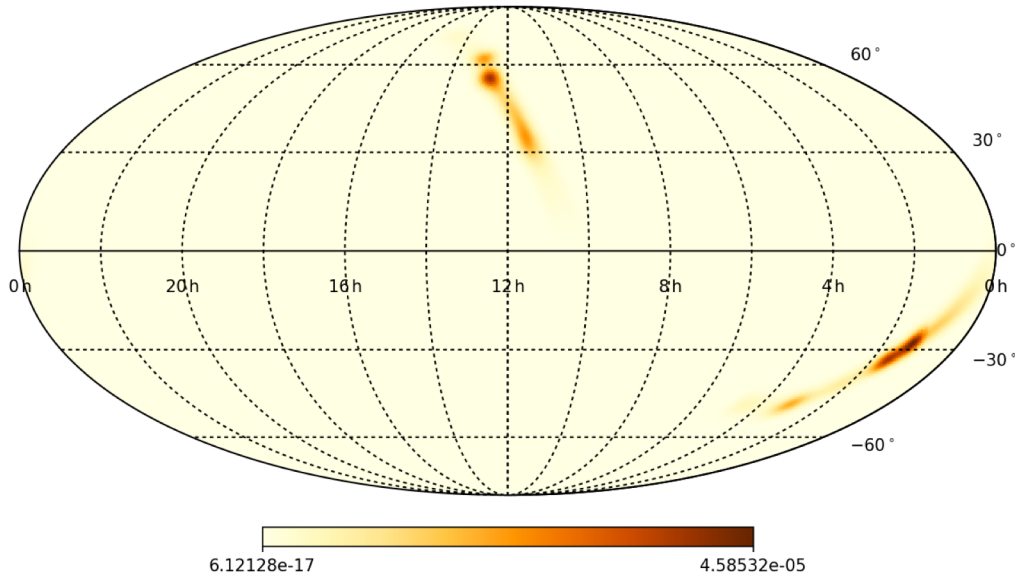

Skymap for LVC S200219ac
gravitational wave candidate

- Receive external multi-messenger alerts for gravitational wave (LIGO/VIRGO) and supernova (SNEWS) event
- Automatically save hitspool data for subthreshold analyses
 - archive to disk and/or transfer via satellite
- 34 LIGO/Virgo-alert hitspool data captures since July 2019

Realtime Neutrino Candidates in IceCube Live

IceCube Realtime

Latest Events

neutrino 2020-03-10 14:56:58.968 3 minutes ago	EHE 2019-09-22 09:42:45.628 6 months ago	ESTRES 2020-03-10 14:06:50.655 an hour ago	HESE 2020-03-10 14:44:35.697 16 minutes ago
---	---	---	--

Event Catalog [show Alerts](#)

Time range: 2020-02-13 04:00:00 → 2020-02-13 04:10:00

Streams
 neutrino EHE ESTRES HESE

Run	Evt #	Event Time	Streams
133726	43085531	2020-02-13 04:09:31	neutrino
133726	42936048	2020-02-13 04:08:39	neutrino
133726	42892542	2020-02-13 04:08:24	neutrino
133726	42775427	2020-02-13 04:07:44	neutrino
133726	42080620	2020-02-13 04:03:45	neutrino
133726	41983928	2020-02-13 04:03:12	neutrino
133726	41674235	2020-02-13 04:01:25	neutrino

Showing 1 to 7 of 7 entries 1 row selected

Previous Next

Latencies ▲

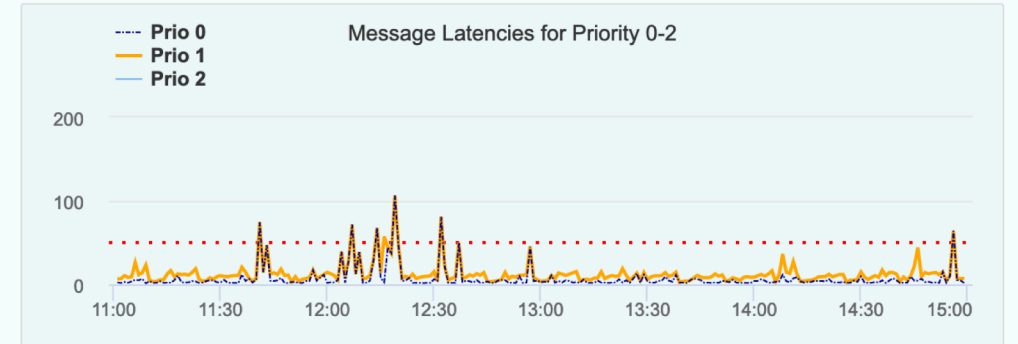

Event Details



Event: run00133726.evt000042775427
Streams: neutrino
Latency: 24s (tx 3s)
Data: data

Realtime Neutrino Alerts in IceCube Live

IceCube Realtime

Latest Events

neutrino 2020-03-10 14:56:58.968 3 minutes ago	EHE 2019-09-22 09:42:45.628 6 months ago	ESTRES 2020-03-10 14:06:50.655 an hour ago	HESE 2020-03-10 14:44:35.697 16 minutes ago
---	---	---	--

Event Catalog

Time range: 20
Streams
neutrino EHE

Run
133726
133726
133726
133726
133726
133726
133726
133726

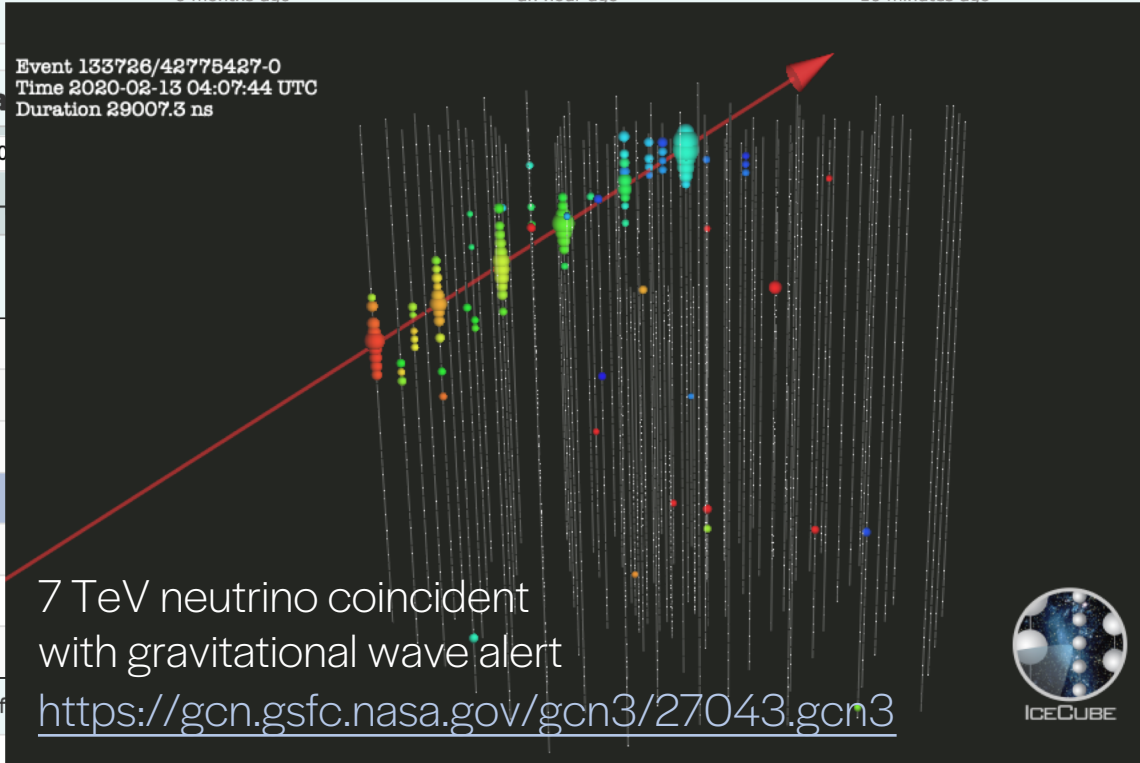

Latencies ⚠

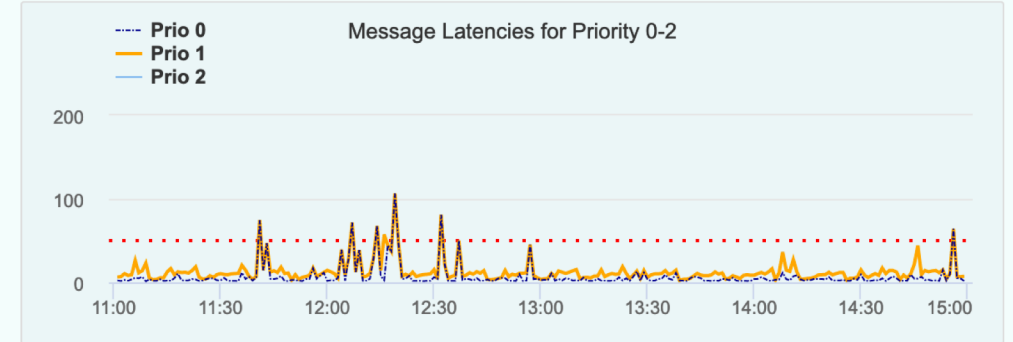

Event Details

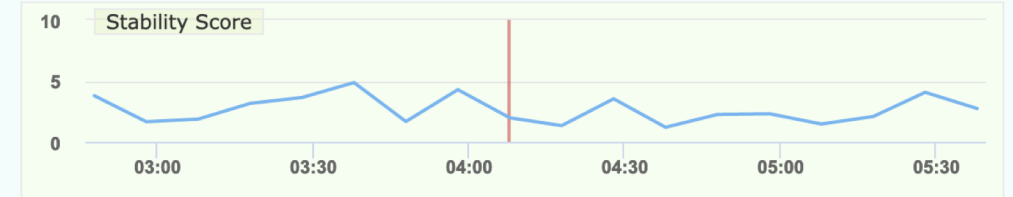

Event: run00133726.evt000042775427
Streams: neutrino
Latency: 24s (tx 3s)
Data: data

DAQ Trigger Efficiency

Urban_Harvest9_rc1 test run CPU usage
(lower is better)

trigger -- CPU utilization

4 Hours (03.03.20 23:09 - 04.03.20 3:09)

Datasource user

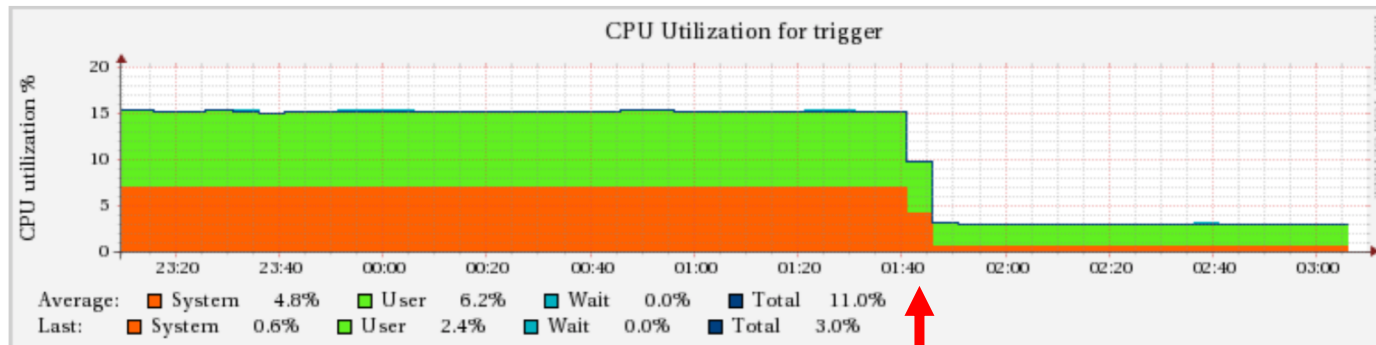

- Server upgrade exposed inefficiency in DAQ trigger code
 - input hit queues bogged down
- Optimized with lock-free queues
 - CPU usage reduced by factor of 5
- Important for the Upgrade
 - no hardware local coincidence
 - more noise hits into trigger
- Changes in computing often require associated changes in software

Preparations for the Upgrade and Beyond

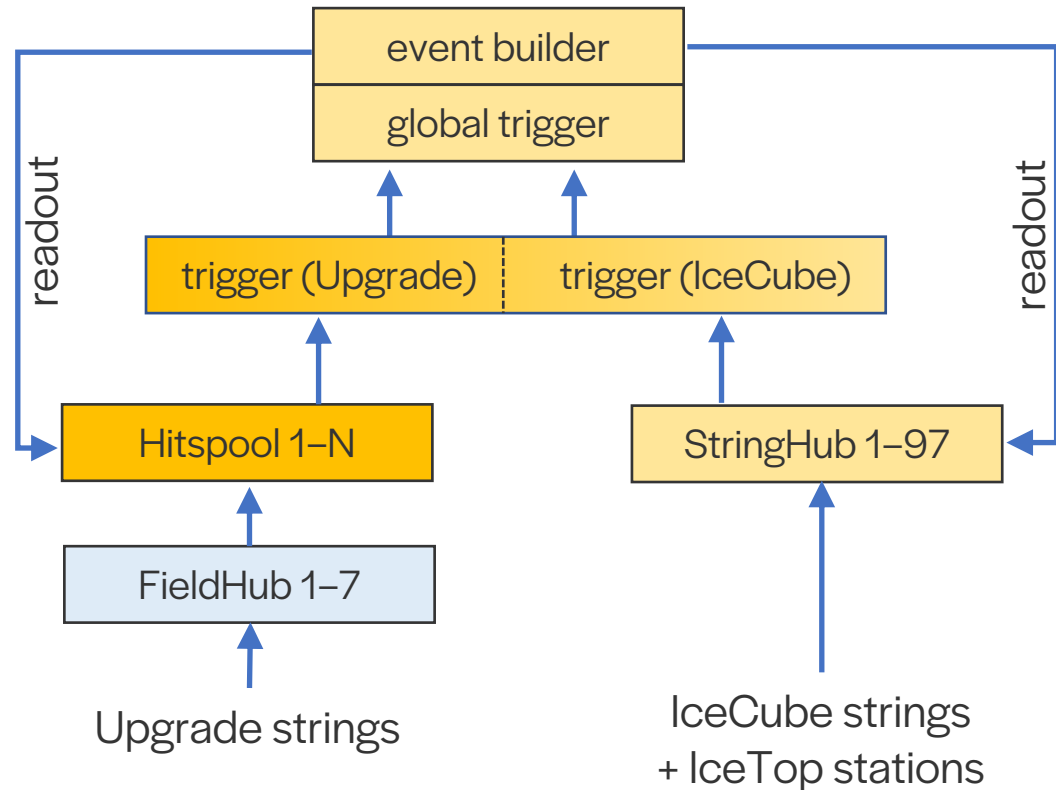

DAQ integration

- M&O development of online software means:
 - major technical risks / fragile systems already replaced
 - architectures designed to be expandable and scalable
- Upgrade will be integrated into IceCube, not the other way around

Summary

- IceCube is operating smoothly
 - through regular and vigilant maintenance
 - addressing problematic hardware and software
- Continuously expanding the science capabilities
- Well-prepared for the Upgrade and beyond
 - investment in maintenance paying off